

# SONY



Sony Digital Recorder  
**HDW-D1800/HDW-1800**



## HDW-D1800/1800 HDCAM Studio Recorders – Cost-effective Solutions for an Even Broader Spectrum of HD Opportunities

Since their introduction in 1997, a huge number of Sony HDCAM™ products have been adopted worldwide in a broad range of production areas such as dramas, documentaries, commercials, news gathering, and digital cinematography. Its stunning picture performance, comprehensive range of products, and bullet-proof reliability have made the HDCAM format the clear choice for these uses. Sony's commitment to continuous product development has now led to the creation of more affordable HDCAM equipment in the form of the new HDW-D1800 and HDW-1800 studio recorders.

Despite their affordable prices, they provide high picture performance, multi-format recording capability including 24P, frame-accurate editing capability, and high reliability – all inherited from the well-known HDW-2000 series VTRs. The HDW-1800 model is a studio edit recorder with HDCAM recording/playback capability, while the HDW-D1800 model

also offers legacy playback of Digital Betacam™ and MPEG IMX™ format tapes with an internal up-conversion capability. Both recorders have a built-in down-converter as standard, enabling SD/HD mixed operations as well as easy integration into existing SD-based editing environments. To accommodate the requirement for emerging HD formats, two types of powerful options are available: HKDW-104 for 720P and 2-3 pull-down output capability, and HKDW-105 for i.LINK™ HDV™ 1080i input. The front panel of both recorders features a jog/shuttle dial, and also a large color LCD screen that displays both playback pictures and various information such as timecode, audio level meters, and operational menus, offering great operational efficiency.

With the new HDW-D1800 and HDW-1800 studio recorders, the solid quality of the HDCAM format can now be easily used in more HD programming opportunities than ever before.

# Features

## High-Definition Picture Quality with the HDCAM Format

The HDW-D1800 and HDW-1800 recorders adopt the proven HDCAM format to record 1920 x 1080 resolution, high-definition component digital signals. The HDCAM format uses an extremely intelligent compression scheme with a high video bit rate of 140 Mb/s (data rate on tape of 185 Mb/s.) This allows the format to provide superb picture quality onto a highly robust and cost-effective 1/2-inch tape, with a design inherited from the Betacam series.

## Interlace/Progressive Switchable Recording and Playback

An important element that makes the HDW-D1800 and HDW-1800 recorders so versatile is their ability to record and play back material recorded in multiple signal formats. They support both interlace and progressive recording modes with the following selectable frame rates: 1080/59.94i, 1080/50i, 1080/29.97PsF, 1080/25PsF, 1080/24PsF, and 1080/23.98PsF.

## Up- and Down-conversion Capabilities with Selectable Picture Modes

The HDW-D1800 and HDW-1800 recorders can output 525/59.94i and 625/50i signals in SD-SDI or analog composite from HDCAM playback. The HDW-D1800 can also output 1080i signals in HD-SDI from SD legacy playback. These up- and down-conversion capabilities provide unlimited operational flexibility. When monitoring such converted signals, the picture display mode can be selected from the following, depending on the type of application.

## Powerful Legacy Playback Capability (HDW-D1800 only)

The HDW-D1800 recorder offers a powerful legacy playback capability for Digital Betacam and MPEG IMX format tapes. This allows flexible use of acquisition tools in the field, and easy integration into existing editing environments.

**Digital BETACAM**

**MPEG IMX**



### SQUEEZE mode

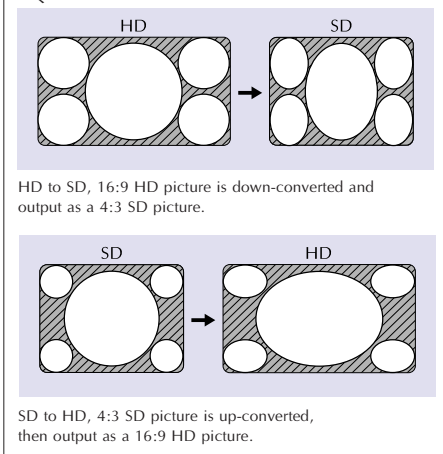

### LETTER BOX mode

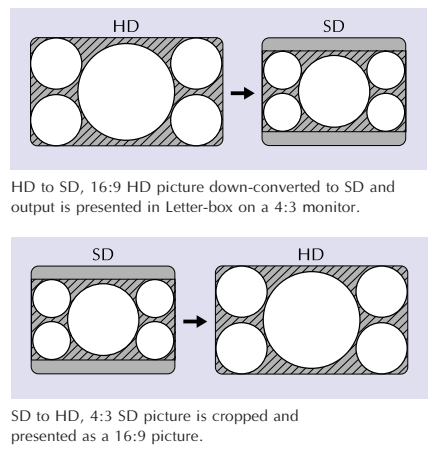

### EDGE CROP mode

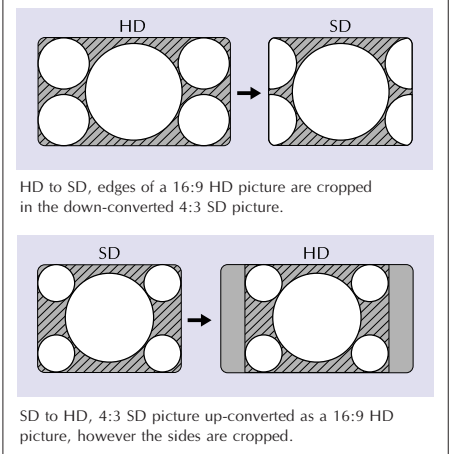

## 720P Conversion and 2-3 Pull-down Output

For further enhanced flexibility, the HDW-D1800 and HDW-1800 recorders provide the ability to output converted 720P signals when playing back 1080i material by use of the optional HKDW-104 board.

This board also provides 2-3 pull-down capability, enabling 23.98PsF/24PsF\* material to be output as 59.94i/60i signals.

\* For 24PsF material, 2-3 pull-down output is available only when it is played back at the system frequency of 23.98 Hz. (In this case, its playback speed is reduced by 0.1%.)

### Converted 720P Output

1080/59.94i, 1080/29.97P, 1080/23.98P, 525*	720/59.94P
1080/50i, 1080/25P, 625*	720/50P

\* Conversion from SD material is available on the HDW-D1800 only.

## HDV 1080i Stream Recording

Responding to the strong demand for a better, more cost-effective process of HDCAM/HDV mixed-format editing, the new HDW-D1800 and HDW-1800 recorders are equipped with a powerful HDV 1080i stream recording capability.

With the addition of the HKDW-105 board, the HDW-D1800 and HDW-1800 recorders can accept an HDV 1080i compatible stream via a single i.LINK cable connection, without any conversion. This is an extremely powerful feature for users who want to shoot in HDV format and post in HDCAM format, or who want to use both HDCAM and HDV material at the same time.

**HDV**  
HDV 1080i

### Supported Frame Rates

Input	Record
HDV 1080/59.94i	HDCAM 59.94i or 29.97PsF
HDV 1080/50i	HDCAM 50i or 25PsF

## Search Functions — Jog and Shuttle Mode

The HDW-D1800 and HDW-1800 recorders deliver recognizable color pictures in shuttle mode at speeds of up to 50 times normal playback.

Jog operation is also possible, at -1 to +2 times normal speed. High-quality jog audio is achieved, providing a responsiveness and sound quality reminiscent of Betacam SP machines.



## 4.3-inch Color LCD Screen

The control panels of these VTRs are simple and easy to use. They are equipped with a 4.3-inch (viewable area, measured diagonally) 16:9 color LCD screen, allowing users to view playback material and VTR setup menus. It is also possible to monitor output signals via 2-3 pull-down or converted 720P signals.



Video Monitor View



System Status View

## Frame Accurate Editing

Insert and assemble editing with frame accuracy is possible on the HDW-D1800 and HDW-1800 recorders. Each video and audio channel can be edited independently.

## Digital Audio Crossfade Function

The HDW-D1800 and HDW-1800 recorders feature Digital Audio Crossfade to achieve smooth audio transitions at audio insert edit points. Previously recorded audio signals are read in advance using pre-read heads and then re-recorded onto the same track after being mixed with the input signal. The crossfade duration can be selected from a range of values.

## Dynamic Motion Control (DMC) Playback

The HDW-D1800 and HDW-1800 recorders also provide a DMC playback capability, which memorizes the tape speed trajectory over the DT (Dynamic Tracking) speed range.

## Pre-read Editing

Equipped with advanced playback heads, these recorders offer a pre-read editing capability. This provides various application functionality, such as tiling with a signal VTR, A/B-roll with two VTRs, audio mix, and channel swap.

## Versatile Interfaces

These recorders feature a wide range of interfaces including:

- HD-SDI input and output
- SD-SDI output
- Analog composite output
- Digital audio input and output
- Analog audio input and output
- Timecode input and output
- Reference input
- RS-422 9-pin remote interface
- Analog audio monitor output
- Video control interface
- Remote parallel 50-pin interface
- RS-232C remote interface

## Easy Setup Using “Memory Stick” Media

With these recorders, users can store and recall VTR setup parameters onto optional Memory Stick™ media, enabling quick and consistent setup of multiple VTRs.

## Metadata Recording

The HDW-D1800 and HDW-1800 recorders are capable of recording metadata including UMID (Unique Material Identifier) and shot marks, which are used for quick cue-up to scenes of interest. This metadata capability improves overall efficiency across the production process.



HDW-D1800 Front Panel

# Rear Panels

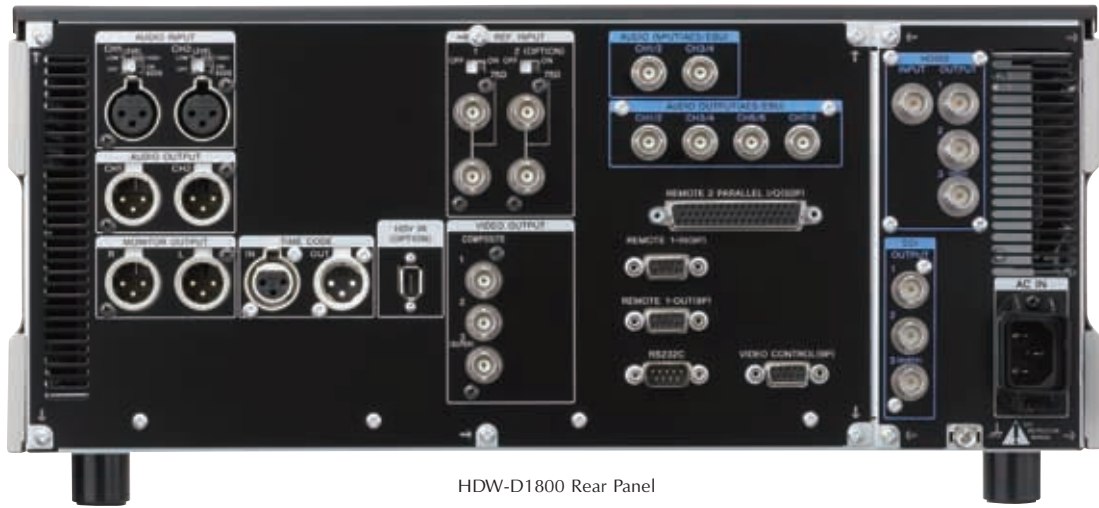

HDW-D1800 Rear Panel

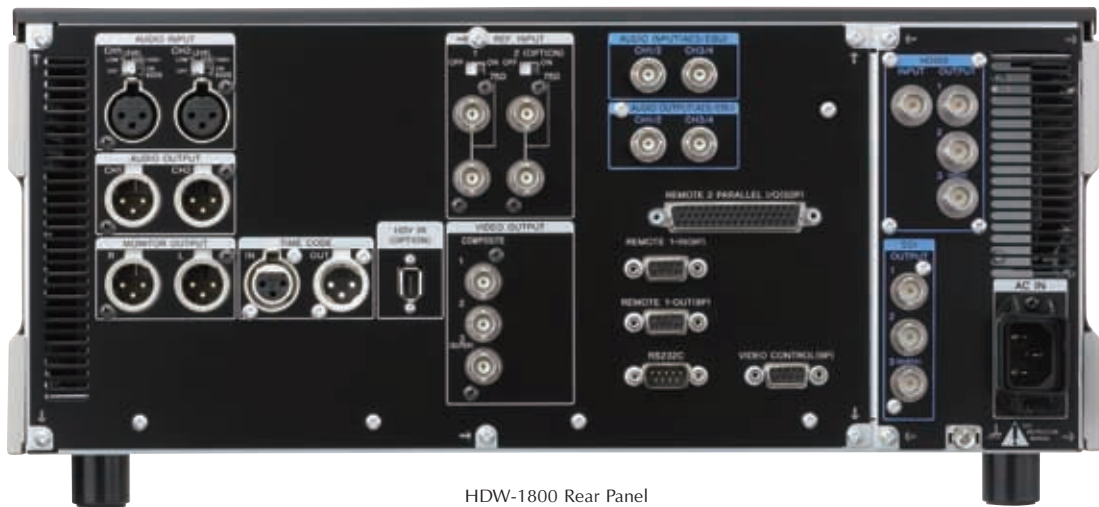

HDW-1800 Rear Panel

# Optional Accessories

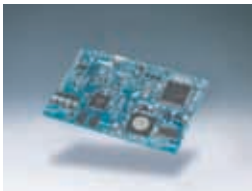

HKDV-104,  
Pull-down/720P Board

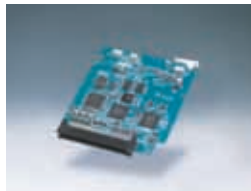

HKDV-105,  
i.LINK (HDV) Input Board



RMM-131,  
Rack Mount Kit



RCC-5G,  
9-pin Remote Cable



RM-280,  
Editing Controller\*1



HKDV-900,  
HD Digital Video Controller\*2



BCT-124HDL/64HDL/22HD,  
HDCAM Tape Cassette



BCT-HD12CL,  
Cleaning Cassette

\*1 Supplied with a 9-pin to 4-pin remote cable (2 meters) for connection to the HDW-D1800/HDW-1800. For longer cable runs, a 10-meter cable is available as an option (1-832-104-11.)  
\*2 To connect the HKDV-900 with the HDW-D1800/1800 VTR, the optional video controller cable, RCC-1505H/1510H/1530H is required.

# HDW-D1800/HDW-1800 Specifications

General	HDW-D1800	HDW-1800																														
Power requirements	100 to 240 V, 50/60 Hz																															
Power consumption	150 W																															
Operating temperature	+5 to +40 °C (41 to 104 °F)																															
Storage temperature	-20 to +60 °C (-4 to +140 °F)																															
Humidity	20 to 90%																															
Mass	22 kg (48 lb 8 oz)																															
Dimensions (W x H x D)	427 x 174 x 544 mm (16 7/8 x 6 7/8 x 21 1/2 inches)																															
Tape speed	<table border="1"> <tr> <td>HDCAM</td> <td colspan="2">96.7 mm/s (59.94i, 29.97PsF), 80.6 mm/s (50i, 25PsF), 77.4 mm/s (24PsF, 23.98PsF)</td> </tr> <tr> <td>Digital BETACAM</td> <td colspan="2">96.7 mm/s</td> </tr> <tr> <td>MPEG IMX</td> <td colspan="2">64.5 mm/s (525/59.94i), 53.8 mm (625/50i)</td> </tr> </table>		HDCAM	96.7 mm/s (59.94i, 29.97PsF), 80.6 mm/s (50i, 25PsF), 77.4 mm/s (24PsF, 23.98PsF)		Digital BETACAM	96.7 mm/s		MPEG IMX	64.5 mm/s (525/59.94i), 53.8 mm (625/50i)																						
HDCAM	96.7 mm/s (59.94i, 29.97PsF), 80.6 mm/s (50i, 25PsF), 77.4 mm/s (24PsF, 23.98PsF)																															
Digital BETACAM	96.7 mm/s																															
MPEG IMX	64.5 mm/s (525/59.94i), 53.8 mm (625/50i)																															
HDCAM record/playback time	<table border="1"> <tr> <td>124 minutes (59.94i, 29.97PsF, with BCT-124HDL cassette)</td> <td colspan="2"></td> </tr> <tr> <td>149 minutes (50i, 25PsF, with BCT-124HDL cassette)</td> <td colspan="2"></td> </tr> <tr> <td>155 minutes (24PsF, 23.98PsF, with BCT-124HDL cassette)</td> <td colspan="2"></td> </tr> <tr> <td>40 minutes (59.94i, 29.97PsF, with BCT-40HD cassette)</td> <td colspan="2"></td> </tr> <tr> <td>48 minutes (50i, 25PsF, with BCT-40HD cassette)</td> <td colspan="2"></td> </tr> <tr> <td>50 minutes (24PsF, 23.98PsF, with BCT-40HD cassette)</td> <td colspan="2"></td> </tr> </table>		124 minutes (59.94i, 29.97PsF, with BCT-124HDL cassette)			149 minutes (50i, 25PsF, with BCT-124HDL cassette)			155 minutes (24PsF, 23.98PsF, with BCT-124HDL cassette)			40 minutes (59.94i, 29.97PsF, with BCT-40HD cassette)			48 minutes (50i, 25PsF, with BCT-40HD cassette)			50 minutes (24PsF, 23.98PsF, with BCT-40HD cassette)														
124 minutes (59.94i, 29.97PsF, with BCT-124HDL cassette)																																
149 minutes (50i, 25PsF, with BCT-124HDL cassette)																																
155 minutes (24PsF, 23.98PsF, with BCT-124HDL cassette)																																
40 minutes (59.94i, 29.97PsF, with BCT-40HD cassette)																																
48 minutes (50i, 25PsF, with BCT-40HD cassette)																																
50 minutes (24PsF, 23.98PsF, with BCT-40HD cassette)																																
Fast forward/rewind time	Approx. 3 minutes (with BCT-124HDL cassette)																															
Search speed range	<table border="1"> <tr> <td colspan="3">Shuttle mode</td> </tr> <tr> <td>HDCAM</td> <td colspan="2">Still to ±50 times normal speed playback (59.94i, 29.97PsF) Still to ±58 times normal speed playback (50i, 25PsF) Still to ±60 times normal speed playback (24PsF, 23.98PsF)</td> </tr> <tr> <td>Digital BETACAM</td> <td colspan="2">Still to ±50 times normal speed playback</td> </tr> <tr> <td>MPEG IMX</td> <td colspan="2">Still to ±78 times normal speed playback</td> </tr> <tr> <td colspan="3">Variable mode</td> </tr> <tr> <td>HDCAM</td> <td colspan="2">-1 to +2 times normal speed playback</td> </tr> <tr> <td>Digital BETACAM</td> <td colspan="2">-1 to +3 times normal speed playback</td> </tr> <tr> <td>MPEG IMX</td> <td colspan="2">-1 to +3 times normal speed playback</td> </tr> <tr> <td colspan="3">Log mode</td> </tr> <tr> <td colspan="3">Still to ±1 time normal speed playback</td> </tr> </table>		Shuttle mode			HDCAM	Still to ±50 times normal speed playback (59.94i, 29.97PsF) Still to ±58 times normal speed playback (50i, 25PsF) Still to ±60 times normal speed playback (24PsF, 23.98PsF)		Digital BETACAM	Still to ±50 times normal speed playback		MPEG IMX	Still to ±78 times normal speed playback		Variable mode			HDCAM	-1 to +2 times normal speed playback		Digital BETACAM	-1 to +3 times normal speed playback		MPEG IMX	-1 to +3 times normal speed playback		Log mode			Still to ±1 time normal speed playback		
Shuttle mode																																
HDCAM	Still to ±50 times normal speed playback (59.94i, 29.97PsF) Still to ±58 times normal speed playback (50i, 25PsF) Still to ±60 times normal speed playback (24PsF, 23.98PsF)																															
Digital BETACAM	Still to ±50 times normal speed playback																															
MPEG IMX	Still to ±78 times normal speed playback																															
Variable mode																																
HDCAM	-1 to +2 times normal speed playback																															
Digital BETACAM	-1 to +3 times normal speed playback																															
MPEG IMX	-1 to +3 times normal speed playback																															
Log mode																																
Still to ±1 time normal speed playback																																
Servo lock time	0.6 s or less (59.94i, 29.97PsF, from standby on), 0.7 s or less (50i, 25PsF, 24PsF, 23.98PsF, from standby on)																															
Load/unload time	6 s or less (both L and S cassettes)																															
<b>Input/output</b>																																
HD-SDI input	BNC x 1 (SMPTE 292M), Serial Digital (1.485 Gb/s)																															
Reference video input 1	BNC x 2 (with a loop-through), Tri-level sync, 0.6 Vp-p, 75 Ω, sync negative, or Black Burst or composite, 0.3 Vp-p, 75 Ω, sync negative																															
Reference video input 2 (option: HKDW-104)	BNC x 2 (with a loop-through), Tri-level sync, 0.6 Vp-p, 75 Ω, sync negative, or Black Burst or composite, 0.3 Vp-p, 75 Ω, sync negative																															
Digital audio input (CH 1/2, CH 3/4)	BNC x 2, AES/EBU																															
Analog audio input (CH 1/2)	XLR-3-pin type, female, x 2 Low off: -60 dBu, high impedance, balanced High off: +4 dBu, high impedance, balanced High on: -4 dBm, 600 Ω termination, balanced																															
Time code input	XLR-3-pin type, female, x 1 (0.5 to 18 Vp-p, 10 kΩ, balanced)																															
i.LINK (HDV 1080i) input (option: HKDW-105)	IEEE1394, 6-pin x1																															
HD-SDI output	BNC x 3 (SMPTE 292M including one character out), Serial Digital (1.485 Gb/s)																															
SD-SDI output	BNC x 3 (SMPTE 259M including one character out), Serial Digital (270 Mb/s)																															
Analog composite output	BNC x 3 (SMPTE 170M, including one character out), 1.0 Vp-p, sync negative, 75 Ω																															
Digital audio output	BNC x 4, AES/EBU (CH 1/2, CH 3/4, CH 5/6, CH 7/8)      BNC x 2, AES/EBU (CH 1/2, CH 3/4)																															
Analog audio output (CH 1/2)	XLR-3-pin type, x 4, male, +4 dBm (600 Ω load), low impedance, balanced																															
Time code output	XLR-3-pin type, male, x 1 (2.2 Vp-p, low impedance, balanced)																															
Monitor output L/R	XLR-3-pin type, male, x 2 (+4 dBm at 600 Ω load, low impedance, balanced)																															
Headphones	JM-60 Stereo phone jack (∞ to -12 dBu at 8 Ω load, unbalanced)																															
Remote1 In	D-sub 9-pin, Sony 9-pin remote interface																															
Remote1 Out	D-sub 9-pin, Sony 9-pin remote interface																															
RS-232C	D-sub 9-pin																															
Remote2 Parallel I/O	D-sub 50-pin																															
Video control	D-sub 9-pin (for connection with the HKDV-900)																															
Others	Memory Stick slot																															
<b>Processor adjustment range</b>																																
Video level	±3 dB/∞ to +3 dB, selectable																															
Chroma level	±3 dB/∞ to +3 dB, selectable																															
Set up/black level	±30 IRE / ±210 mV																															
Chroma phase/hue	±30°																															
System sync phase	±15 μs																															
System SC phase	±200 ns																															
<b>Digital video performance</b>																																
Sampling frequency	Y: 74.25 MHz, R-Y/B-Y: 37.125 MHz																															
Quantization	10 bit/sample (compression: 8 bit/sample)																															
Compression	Coefficient recording system																															
Channel coding	S-I-NRZI PR-IV																															
Error correction	Reed-Solomon code																															
<b>Analog composite output</b>																																
Bandwidth	0 to 5.75 MHz +0.5 dB/-3.0 dB																															
S/N ratio	53 dB or more																															
Differential gain	2% or less																															
Differential phase	2° or less																															
Y/C delay	20 ns or less																															
K Factor (2T Pulse)	1% or less																															
Output SCH phase	Based upon RS-170A/CCIR R.624-3																															

	HDW-D1800	HDW-1800
<b>Digital audio performance</b>		
Sampling frequency	48 kHz (Synchronized with video)	
Quantization	20 bits/sample	
Wow & flutter	Below measurable level	
Headrooms	20 dB (or 18 dB selectable)	
Emphasis (ON/OFF selectable in REC mode)	T1=50 μs, T2=15 μs (on/off selectable in recording mode)	
<b>Analog audio output performance</b>		
Frequency response	20 Hz to 20 kHz +0.5 dB/-1.0 dB (0 dB at 1 kHz)	
Dynamic range	More than 95 dB (at 1 kHz, emphasis ON)	
Distortion	Less than 0.05% (at 1 kHz, emphasis ON, reference level)	
Crosstalk	Less than -80 dB (at 1 kHz, between any two channels)	
<b>Cue track</b>		
Sampling frequency	100 Hz to 12 kHz ±3 dB	
S/N ratio	More than 45 dB (at 3% distortion level)	
Distortion	Less than 2% (THD at 1 kHz, reference level)	
Wow & flutter	Less than 0.2% rms	
<b>Digital Betacam playback performance</b>		
Video		
Bandwidth	Y: 0 to 5.75 MHz +0.5 dB/-0.5 dB R-Y/B-Y: 0 to 2.75 MHz +0.5 dB/-0.5 dB	-
S/N ratio	62 dB or more	-
K-factor	1% or less	-
Digital audio (CH 1 to 4)		
Frequency response	20 Hz to 20 kHz +0.5 dB/-1.0 dB	-
Dynamic range	95 dB (at 1 kHz, emphasis ON)	-
Distortion	0.05% or less (at 1 kHz, emphasis ON, reference level (+4 dBm))	-
Wow & flutter	Below measurable level	-
Analog audio (cue track)		
Frequency response	100 Hz to 12 kHz +3 dB/-3 dB	-
S/N ratio	45 dB or more (at 3% distortion level)	-
Distortion	2% or less (THD at 1 kHz, reference level)	-
Wow & flutter	Less than 0.2% rms	-
<b>MPEG IMX playback performance</b>		
Video		
Bandwidth	Y: 0 to 5.75 MHz +0.5 dB/-2.0 dB R-Y/B-Y: 0 to 2.75 MHz +0.5 dB/-2.0 dB	-
S/N ratio	56 dB or more	-
K-factor (2T pulse)	1% or less	-
Digital audio (CH 1 to 8)		
Frequency response	20 Hz to 20 kHz +0.5 dB/-1.0 dB (0 dB at 1 kHz)	-
Dynamic range	90 dB or more (at 1 kHz, emphasis ON, 16 bits/48 kHz)	-
Distortion	0.05% or less (at 1 kHz, emphasis ON, reference level (+4 dBm))	-
<b>Others</b>		
Supplied accessories	Operation manual (CD-ROM x1), Installation manual (x1), Operation guide (x1), PSW 4x16 rack mount screw (x4)	

# SONY



Distributed by

©2009 Sony Electronics Asia Pacific Pte. Ltd. All rights reserved.  
Reproduction in whole or in part without written permission is prohibited.  
Features and specifications are subject to change without notice.  
All non-metric weights and measurements are approximate.  
Sony, HDCAM, CineAlta, Digital Betacam, MPEG IMX, Betacam, i.LINK and  
Memory Stick are trademarks of Sony.  
HDV is a trademark of Sony Corporation and Victor Company of Japan, Limited.

[pro.sony-asia.com](http://pro.sony-asia.com)